

**DEPÓSITO CENTRAL DE VALORES**



**Disclosure Framework  
Principles for Financial Market Infrastructures  
(PFMI)**

**April 2024**

Responding institution: **Depósito Central de Valores**

Jurisdiction in which the FMI operates: **Chile**

Authority regulating, supervising or overseeing the FMI: **Comisión para el Mercado Financiero**

The date of this disclosure is: **30/03/2023**.

This disclosure can also be found at <https://www.dcv.cl/en/>

For further information, please contact **Jaime Cristian Peña** ([cpena@dcv.cl](mailto:cpena@dcv.cl))

## GLOSSARY

AFP	Administradora de Fondos de Pensiones (Pension Fund Management Company)
BCP	Business Continuity Plan
BCCh	Banco Central de Chile (Central Bank of Chile)
BCS	Bolsa de Comercio de Santiago (Santiago Stock Exchange)
BEC	Bolsa Electrónica de Chile (Electronic Stock Exchange of Chile)
BIA	Business Impact Analysis
CCP	Central Counterparty
CCLV	CCLV Contraparte Central S.A. (CCLV Central Counterparty Ltd.)
CMF	Comisión para el Mercado Financiero (Financial Market Commission)
CSD	Central Securities Depository
CPSS	Committee on Payment and Settlement Systems
DVP	Delivery versus Payment
FMI	Financial Market Infrastructure
GRC	Governance, Risk Management and Compliance
IMF	International Monetary Fund
IOSCO	International Organization of Securities Commission
ISAE	International Standard on Assurance Engagements
ISO	International Standards Organization
KC	Key Consideration
MILA	Mercado Integrado Latinoamericano (Integrated Latin American Market)
MOF	Ministry of Finance
MOU	Memorandum of Understanding
NGC	Norma de Carácter General (general rule)
OLA	Operational Level Agreement
OTC	Over the Counter
PFMI	Principles for Financial Market Infrastructures
PS	Payment System
RPO	Recovery Point Objective
RTGS	Real time gross settlement system
RTO	Recovery Time Objective
SBIF	Superintendencia de Bancos e Instituciones Financieras (Superintendence of Banks and Financial Institutions)
SLA	Service Level Agreement
SP	Superintendencia de Pensiones (superintendence of pensions)
SRAD	Sitio de Recuperación ante Desastres (disaster recovery site)
SSS	Securities Settlement System
SWIFT	Society for Worldwide Interbank Financial Telecommunication
UF	Unidad de Fomento

<b>I – EXECUTIVE SUMMARY</b> .....	5
<b>II – SUMMARY OF MAJOR CHANGES SINCE THE LAST UPDATE OF THE DISCLOSURE</b> .....	6
<b>III – GENERAL BACKGROUND ON THE FMI</b> .....	7
<b>A. General description of the DCV and the markets it serves</b> .....	7
<b>B. General organization of the DCV</b> .....	11
<b>C. Legal and regulatory framework</b> .....	14
<b>D. System design and activities of DCV</b> .....	16
<b>IV – PRINCIPLE BY PRINCIPLE SUMMARY DISCLOSURE</b> .....	18
<b>Principle 1: Legal Basis</b> .....	18
<b>Principle 2: Governance</b> .....	21
<b>Principle 3: Framework for the Comprehensive Management of Risks</b> .....	25
<b>Principle 10: Physical Deliveries</b> .....	29
<b>Principle 11: Central Securities Depositories</b> .....	30
<b>Principle 16. Custody and Investment Risks</b> .....	37
<b>Principle 17: Operational Risk</b> .....	39
<b>Principle 18. Access and Participation Requirements</b> .....	45
<b>Principle 19. Tiered Participation Arrangements</b> .....	47
<b>Principle 20. FMI Links</b> .....	48
<b>Principle 21: Efficiency and Effectiveness</b> .....	50
<b>Principle 22: Communication procedures and standards</b> .....	51
<b>Principle 23: Disclosure of Rules, Key procedures, and Market Data</b> .....	52

## I – EXECUTIVE SUMMARY

This Disclosure Framework regarding the implementation of compliance with the "Principles Applicable to Financial Market Infrastructures" (PFMI) by the Central Securities Depository (DCV), aims to explain to its users, authorities and the general public how the DCV, has implemented and complies with the PFMI.

It should be recalled that the PFMI, published in April 2012 by CPMI-IOSCO, comprehensively addresses aspects of the management of Financial Market Infrastructures (FMI), with a particular focus on factors such as risk management, corporate governance, legal framework, operational strength, and transparency.

The PFMI is composed of 24 principles, of which 14 are applicable to all FMIs regardless of their role, one of the principles is applicable exclusively to centralized securities depositories (CSDs), while 6 principles are applicable exclusively to securities settlement systems (SSS). while 2 principles are applicable only to the function of central counterparty exchanges (CCPs).

The Disclosure Framework contributes to a clearer understanding of the DCV activities, as well as its risk profile and risk management practices, thus supporting sound decision-making by its stakeholders. To this end, principle 23 of the PFMI establishes the need for Financial Market Infrastructures to promote transparency towards the public and stakeholders through the Disclosure Framework, which should be based on the "Disclosure and Evaluation Framework Methodology" published in December 2012 by CPMI-IOSCO.

In terms of the principles applicable to the DCV and the assessment methodology, the DCV operates only as a central securities depository (CSD) and therefore Principles 1, 2, 3, 10, 11, 15, 16, 17, 18, 20, 21, 22 and 23 apply to it. All principles applicable to CSD were evaluated based on the document "PFMI: Disclosure Framework and Evaluation Methodology" published in December 2012 by CPSS-IOSCO.

The DCV was created in 1993 and its business operations began in 1995. The DCV acts as a central securities depository (CSD) in Chile and is the only entity that provides this service in the country. It is a user-owned entity, which includes among its shareholders domestic brokers (through stock exchanges) and institutional investors.

The DCV provides safekeeping of public offering securities, principally those held by institutional investors (insurance companies, banks, pension funds and investment funds), as well as those held in custody by brokers, either on their own account or on behalf of their clients. Likewise, the DCV electronically registers the issuance of securities and facilitates the transfer of ownership resulting from the securities trading carried out by its depositors, which originate both in the exchange market and in the over the counter market (OTC).

The DCV has six different business units: 1) national custody, 2) international custody, 3) registrar services, 4) statistics, 5) documents and 6) guarantees.

The principal legal body that regulates the DCV is the Law 18,876 ("*That Establishes the Legal Framework for the Constitution and Operation of Private Securities Depository and Custody Entities*"). The DCV is regulated and overseen by the Financial Market Commission of Chile (CMF).

Because the entity operates only as a CSD, without carrying out the functions of a securities settlement system (SSS), it is exposed only to operational risk, custody risk and general business risk, but is not exposed to credit or liquidity risks.

## **II – SUMMARY OF MAJOR CHANGES SINCE THE LAST UPDATE OF THE DISCLOSURE**

During 2022, the DCV launched its new securities deposit system, Nasdaq CSD (NCSD), developed by the company Nasdaq. The completion of this implementation project named "DCV Evolution", which began in 2018, allows the DCV to have a new technology that will enable the standardization and unification of operations, messaging and data infrastructure, along with greater flexibility and profitability for the company.

In regulatory matters, there have been two significant changes since the last Disclosure Framework. In December 2022, Law 21,521 was enacted, called "Fintec Law" ("Promotes competition and financial inclusion through innovation and technology in the provision of financial services, FINTEC law"), which expressly authorizes the DCV to participate in new businesses and markets, corresponding to Fintech models, and the CMF, through a complementary regulation, has authorized the DCV to custody tokenized assets, in particular, those linked to securities previously authorized by the CMF.

On the other hand, in December 2023, the Financial Resilience Act was enacted which, as far as the DCV is concerned, authorizes the BCCH to open current accounts to the DCV, as well as to provide banking services to the DCV. In addition, this law empowers the CSDs to manage clearing and settlement systems for financial instruments and to create a subsidiary company to manage clearing and settlement systems.

With regard to its internal organization, the CSD has adapted its management structure in light of the implementation of the NCSD. In this sense, the Architecture and Development Management, and the Operations and Processes Management have been created.

### III – GENERAL BACKGROUND ON THE FMI

#### A. General description of the DCV and the markets it serves

DCV maintains in custody public offering securities, principally those owned by institutional investors (insurance companies, banks, pension fund managers and investment funds), as well as held by stockbrokers, either on their own account or on behalf of customers. Together with maintaining the custody of securities, DCV electronically registers the operations and facilitates the transfer of ownership, which are a result of the securities trading carried out by its depositors. The latter originate both in the stock market and in the over the counter market (OTC).

In its capacity as a CSD, DCV is linked with practically all the participants in the Chilean financial market, as shown in the following diagram. In this way, it relates to investors, as DCV depositors, through the offer of custody services and the execution of instructions for the transfer of securities traded, either in stock exchanges or in the OTC market. Likewise, in securities settlement, it is related operationally to payment systems (PS) and securities settlement systems (SSS). On the other hand, it interacts with the issuers of public offering securities, while those carry out their securities placement using DCV services and, in the case of corporations, the DCV subsidiary, DCV Registros, manages the shareholder registries and corporate events of a large part of Chilean companies. Finally, DCV is subject to the surveillance of the Financial Market Commission (CMF) and, on the other hand, it permits various authorities to access information for their regulatory work.

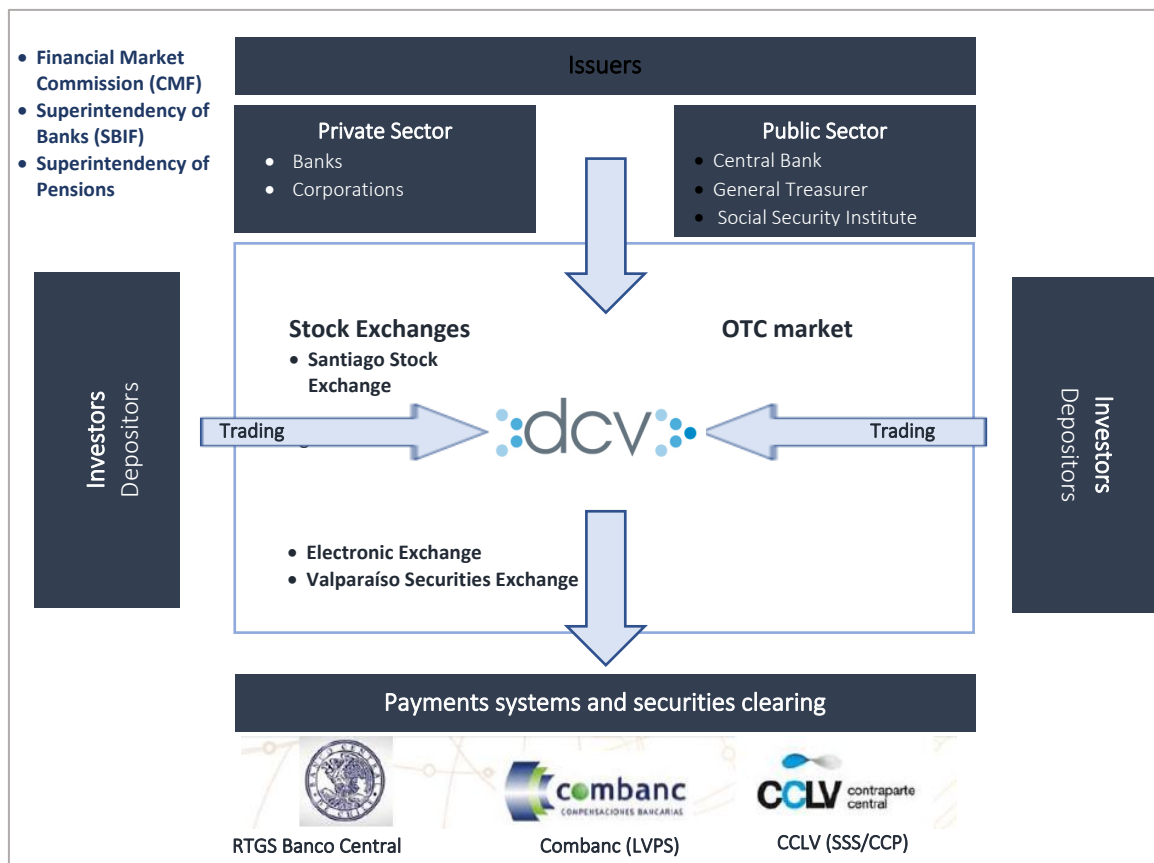

## **Business Units**

DCV has six different business units: 1) National custody, 2) International custody, 3) Shareholders Registries, 4) Statistics, 5) Collateral and 6) Services and consulting.

### **1. National**

It is the principal business area of the DCV and includes the depository and management of securities issuers and services to the depositor's customers ("*mandantes*").

Depository services include the custody of domestic securities, as well as the registration and settlement of operations, accounts management, certificate of holdings issuance, use of liquidity facilities with the Central Bank, and the payment of corporate events. Although more than 97% of the deposited securities are dematerialized, DCV maintains some securities in physical form, mainly social security bonds and some corporate bonds.

The securities issuers management services involve the registration of issues, the securities dematerialization service and the representation in Chile of ANNA (ISIN code assignment).

The depositors' customer's services consider the provision of services to the clients of the depositors ("*mandantes*") that maintain their own account with DCV, allowing them the custody, the registration and settlement of operations, the accounts management, and the securities administration.

### **2. International Custody**

This business unit includes two principal service lines: the depository services and the Omgeo service.

The international depository services allow depositors who hold securities abroad to safeguard these investments through the CSD in a similar way as with the custody of domestic securities.

On the other hand, the main objective of the Omgeo service is to facilitate communication between brokers and investors during the process of "*matching post-trade and pre-settlement*" of operations.

### **3. Administration of Shareholder Registries**

The third business unit consists of the management of shareholder and investment fund investor records. The management of the shareholder registry includes shareholder assistance, the updating of their background information, the shareholder registry database maintenance and the processing of stock transfers. On the other hand, the maintenance of investment funds investor records includes investor assistance, the updating of their background information, the investor database maintenance, and the processing of fund unit transfers.

The management of corporate events involves the summons for shareholders' meetings, the management of capital offerings and preferred capital offerings, withdrawal rights, dividend payments and other activities.

DCV also monitors shareholders and investors, by verifying their inclusion in OFAC lists and it carries out legal reports and advisory services associated with the latter.

#### **4. Statistics**

The statistics service includes reports for other FMIs (e.g., Comder, Central Bank), transaction reports, custody reports, securities catalog, securities maturities, among others.

Additionally, this line of business includes portfolio valuation, especially those managed by the pension fund managers (AFP).

#### **5. Collateral**

DCV has developed the service of collateral registration in certain areas, such as the notary certified pledge, the electronic pledge management and special pledges as well as mining guarantees. All of these activities include in the registration, releasing and custody of the respective pledge.

#### **6. Services and Consulting**

The services offered in this business category include the centralised registration service of forward contracts between banks, and between banks and pension funds managed by AFPs. Also belonging to this business unit is the registration and custody service of certain pension bonds, known as "recognition bonds", which are issued by the State of Chile (through the Social Security Institute), and are payable to pensioners who managed to contribute to the old pay-as-you-go pension system. Likewise, this business unit includes the Active Affiliate Recognition Bonus (BRAA) management platform, which provides value-added services on top of BRAAs. Finally, advice and services include the service of Responsible Tax Agent, which carries out tax representation activities for foreign investors.

## Main Statistics

### **Main statistics (December 2023)**

Total domestic securities under custody	US\$ 319 billion
Percentage of fixed income securities under custody	71,9%
Percentage of equity securities under custody	28,1%
Number of depositors	186
Percentage of dematerialized securities	98,8%
Total securities transferred in December 2019	US\$ 182.600 millones
Number of securities transferred in December 2019	118.050
Total international custody	US\$ 3,5 billion

### **Amount under custody (USD million)**

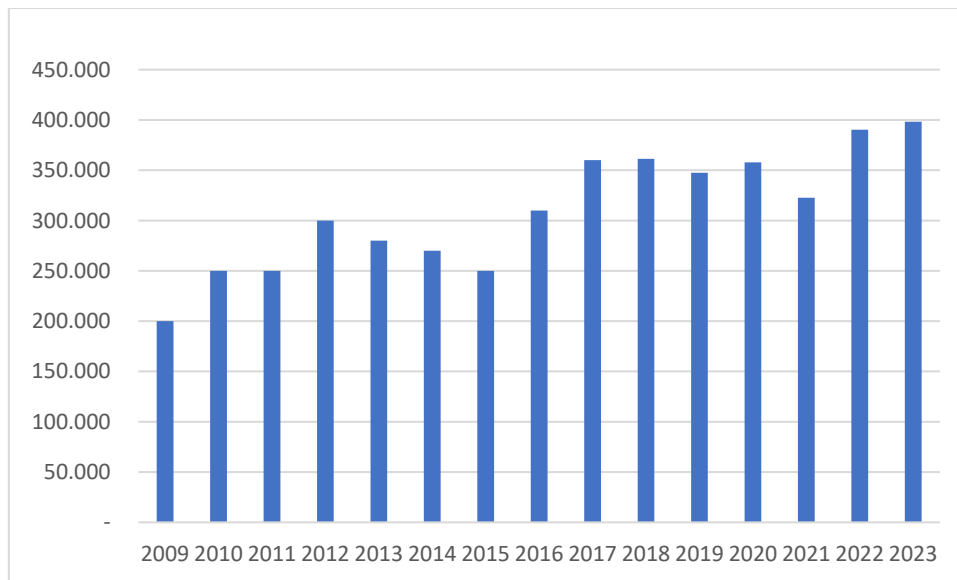

**Types of securities under custody**

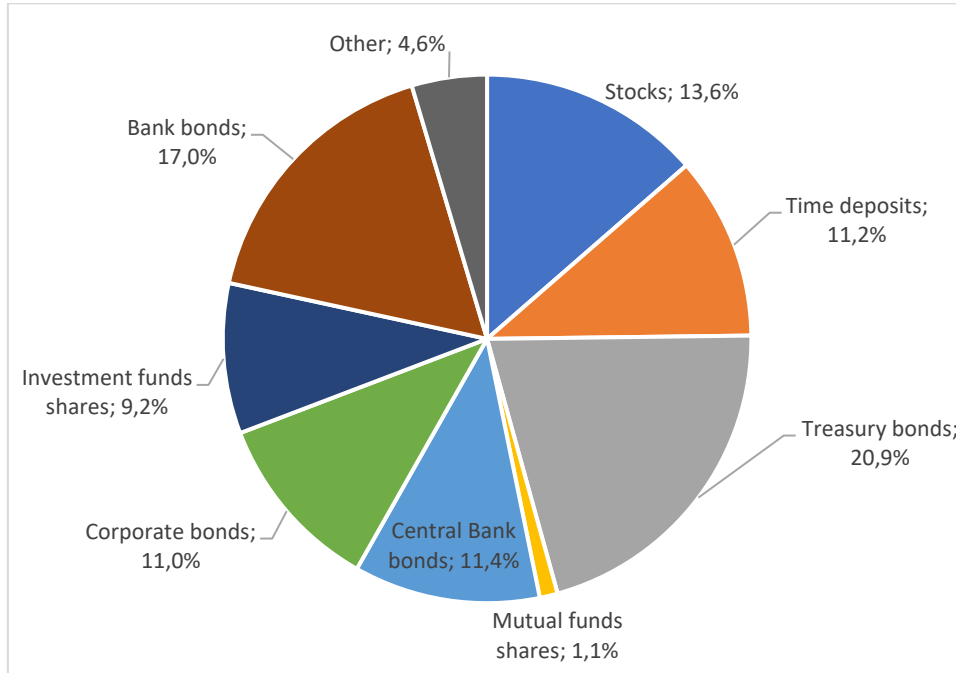

**B. General organization of the DCV**

DCV is constituted as a public limited company in accordance with Law 18,876 and therefore, in terms of corporate governance, the provisions of the Public Limited Companies Act (Law 18,046) are applicable. It has a subsidiary, DCV Registros, dedicated to the management of shareholder and fund investor registries.

Its main shareholders are the domestic banks (30%), pension fund managers (30%), the Santiago Stock Exchange (23%), insurance companies (10%), the Electronic Stock Exchange (6%) and the Valparaíso Stock Exchange (1%).

In the DCV shareholders' meeting, the shareholders nominate the DCV board of directors, composed of 10 members, who hold office for two years and can be re-elected indefinitely.

The board of directors has five committees (audit and operational risk, business, technology and processes, and compensation and human resources), the functions of these being the following:

- **Audit Committee:** Supervises the work of the internal audit function carried out by the Comptroller's Office; analyzes and concludes on the reviews of the external auditors and the CMF; analyzes financial statements for reporting to the Board; is informed about transactions between related parties; identifies conflicts of interest and on suspicious acts and conduct and fraud; determines the performance of special audits, and report to the Board of Directors. This committee is composed of three members of the Board of Directors and meets at least 8 times a year.

- Customer and Business Development Committee: Defines, analyzes and proposes to the Board of Directors: the Mission, Vision and Values; relevant business initiatives and their target market; modifications to current services; fees for current and future services; any other strategic initiative that the DCV intends to pursue. It also analyzes next year projections, the strategic plan, and investments. This committee is composed of three members of the Board of Directors and meets at least 6 times a year.
- Risk and Cybersecurity Committee: Assists the Board of Directors in fulfilling its oversight responsibilities in relation to risk management. This committee serves as support for decisions related to risk management in the organization, as part of the second line of defense, in accordance with the responsibilities defined in the company's bylaws and in the board of directors' regulations. It supervises the agreements adopted by the Board of Directors, related to the organization's risk policy and management, considering within the scope defined in the general risk policy and supervises compliance management within the framework of the different dimensions regarding the crime prevention model, as well as the laws and regulations that apply to the company. This committee is composed of three members of the Board of Directors and meets at least 6 times a year.
- Technology and Processes Committee: Analyzes and defines the medium and long-term technology vision of the company, as well as any initiative to improve the technological area, proposes priorities and allocates resources for the different projects. This committee is composed of three board members, one of whom is appointed by the other members as the president and an external adviser and meets every two months.
- People Management Committee. Defines and approves the staff remuneration and benefits policies and the remuneration of the General Manager and area managers; The parameters, criteria and variables for the calculation of the annual incentive plan and reviews and sanctions the policies proposed by the People Management Department. This committee is composed of three members of the Board of Directors and meets at least 2 times a year.

The executive management of the DCV is led by its General Manager, who in turn reports directly to the Board of Directors. In addition to the General Manager, there are nine senior managers as shown in the box below.

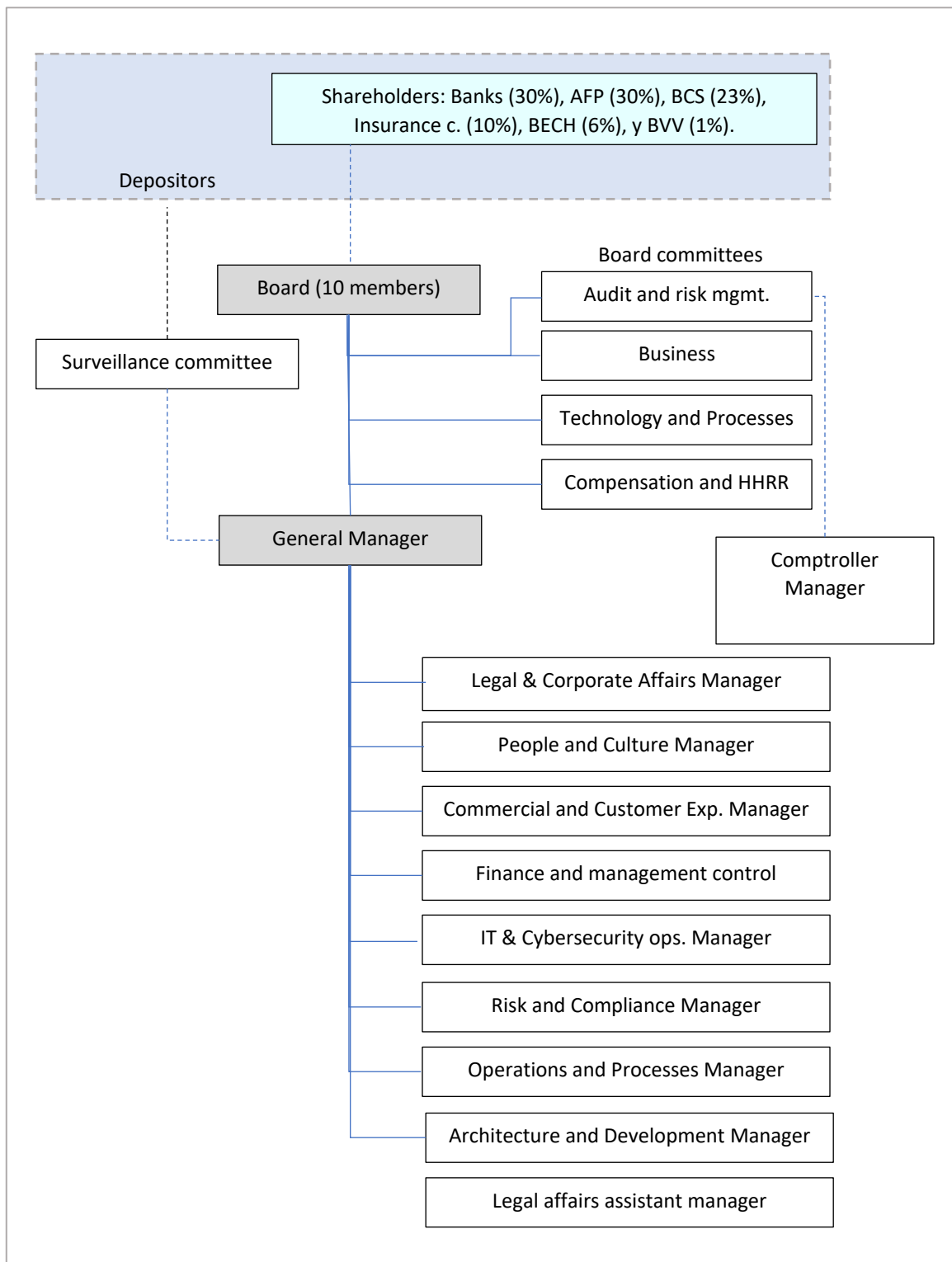

The DCV depositors meet in ordinary or extraordinary meetings or assemblies. The first are held once a year, to decide on issues that are specific to their matter. The second may be held at any time, when so determined by DCV or when requested by the Surveillance Committee or the depositors.

The Surveillance Committee is an entity created and regulated by the Law 18,876, which oversees the company's internal operations and those carried out with it by the depositors. As provided by the Law,

this committee is composed of 5 representatives of the depositors, and is vested with the following powers:

- a.- Verify that the custody, clearing, settlement and transfer operations are fully and timely fulfilled;
- b.- Practice, quarterly, the company's securities audit and verify the accuracy and match of the depositor accounts;
- c.- Verify that the information available to depositors is sufficient, truthful and timely;
- d.- To verify if the depositors timely and satisfactorily fulfil their obligations both with respect to other depositors and with the company itself;
- e.- Verify the quality of the facilities and security systems; as well as the quality and amount of guarantees and insurance in force;
- f.- To inform the CMF of the deficiencies, differences and irregularities they may encounter, suggesting the measures that they deem pertinent and appropriate to overcome them or to prevent their repetition,
- g.- To inform in the depositors' meeting of any situation that may affect their interests, and
- h.- Any other issue that is deemed necessary for the proper security of the system.

### **C. Legal and regulatory framework**

The principal legal body that regulates the DCV is the Law 18,876 ("*That Establishes the Legal Framework for the Constitution and Operation of Private Securities Depository and Custody Entities*"). This law establishes the legal basis of the contract of the depository, who can be accepted as participants of the company, the main relationships between the participants and the company, the legal implications of the actions of the company, including transfers, pledge constitution, securities ownership, settlement finality and the company responsibilities.

The Law 18,876 also establishes the operational requirements, including the existence of an Internal Regulation that deals with the relationship between the company and the depositors and requires a public fee study that supports the fee structure. Likewise, it establishes the existence of the depositors' assembly, which has as its main purpose the nomination of the Surveillance Committee and the determination of its annual goals, the monitoring of these tasks and those imposed by the law itself on the committee. The Law also contemplates the procedure for dealing with net equity deficits, including procedures of reorganization and orderly liquidation.

It is relevant to mention that the so-called Productivity Law, promulgated in 2016, established a series of changes to the Law 18,876. Among these modifications, the following stand out:

- Broadens the nature of the instruments that securities depositories can custody, by allowing the deposit of other goods, documents and contracts authorized by the CMF.
- Creates a new type of pledge called "special pledge" that facilitates the pledge constitution and release by electronic means, and allows its execution by simple instructions and transfers. This provision can expedite the use of collateral in various environments, including in the securities clearing system and in a stock exchange.
- Authorizes to constitute or to participate in the ownership of a subsidiary whose main purpose is to

carry out activities that are related, complementary or ancillary to the purpose of the depository company.

- Empowers DCV to represent the depositors in shareholder meetings and to exercise the voting right in these, as well as to participate in the subscription and payment of public offer securities on their behalf, and to collect and receive amortizations, interest, dividends, distributions and other benefits to which depositors are entitled.

On the other hand, Supreme Decree 734 (issued by the Ministry of Finance), establishes the procedure for the approval of the operation of the depository companies, the content of the Internal Regulation, as well as the Depository Contract that the company must sign with each one of its depositors. It also includes provisions regarding the deposit and withdrawal of securities, the opening and closing of accounts and the obligations of information and monitoring, such as the presentation of financial statements and the obligation of external audit with respect to its own operations and those concerning to the securities custody activity.

DCV's supervisory authority is the Financial Market Commission (CMF)<sup>1</sup>, whose function is to oversee and regulate the insurance industry and the securities market, including stock exchanges, fund managers, securities intermediaries, public limited companies and financial market infrastructures.

At the level of regulation issued by the supervisory authority, the following rules stand out:

#### Circular 1939

This instructs on the implementation of the operational risk management in the deposit and custody and the clearing and settlement systems managing entities. For the development of this circular, the main international standards on this subject have been considered, to ensure appropriate risk management practices to count on market infrastructures capable of dealing with the risks that affect them.

#### General Rule 220

This General Rule regulates the information to be sent by the depository entities regarding new inherent or complementary activities to be implemented and the authorization procedures of these, in order that the authorities and the market take notice of them, and be able to understand the form in which they are inserted in the going concern of the entity, to learn the risks that this activity contributes to the system, as well as to determine the existence of proper risk control mechanisms, aimed at ensuring the correct functioning of the securities settlement system

#### General Rule 224

In consideration that the Law 18,876 requires the depository company to provide a fee study that supports its fee structure, this General Rule establishes minimum contents for the preparation of this fee study to be provided by the securities depository entities.

---

<sup>1</sup> <http://www.cmfchile.cl>

## General Rule 223

This deals with the information that must be made available by depository entities to the depositors' customers that hold an individual account, as referred to in Article 179 of the Law 18,045.

## Circular 2020

This Circular presents the instructions to be fulfilled by the depository entities as well as securities clearing and settlement entities, referring to communication, management and resolution of critical operational incidents that affect the normal development of its services, to ensure compliance with proper standards in relation to its services performance, availability and safety.

### D. System design and activities of DCV

The following diagram presents an overview of the architecture of the financial market infrastructures (FMI) in Chile.

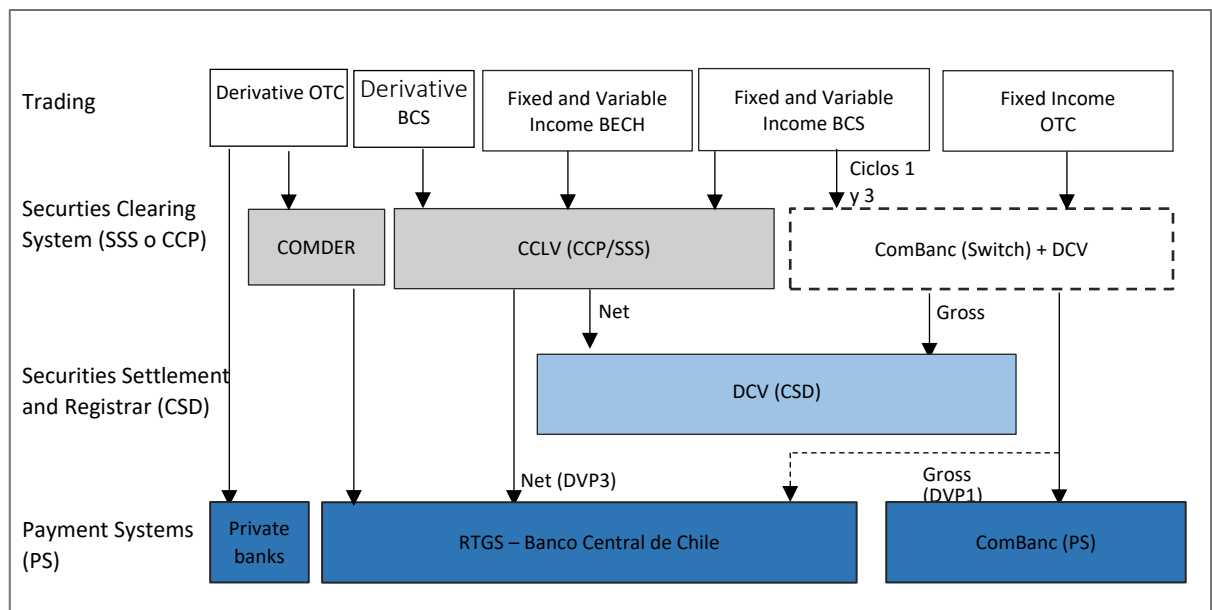

#### Main risks

The DCV is exposed to operational risk and custody risk, as well as business risk. However, it is not exposed to credit or liquidity risks. Operational risk management is oriented at assessing and managing the risks associated to the following categories:

#### People

It refers to the risk of losses, being they intentional or not, caused by, or that involve, employees. This kind of risk causes problems to the internal organization and losses.

#### Relations with third parties

It refers to losses caused to the Company that are generated through the relationships or contacts that the firm has with its customers, shareholders, third parties, regulators and interest groups.

#### Processes

It refers to the risks related to the execution and maintenance of the operations and the variety of aspects of the business execution, including products and services.

#### Technological

Refers to risks of losses caused by piracy, theft, failures, interruptions or other disruptions in technology, data or information; it also includes technology that does not contribute to achieving business objectives.

#### External

It refers to risk of losses due to damage to tangible property or intangible assets due to natural causes or others. This category of risk also includes actions caused by external agents, such as in the performance of a fraud. In the case of regulators, the enactment or change that could alter the continuity of the firm to continue operating in a certain market.

## IV – PRINCIPLE BY PRINCIPLE SUMMARY DISCLOSURE

### Principle 1: Legal Basis

**An FMI should have a well-founded, clear, transparent, and enforceable legal basis for each material aspect of its activities in all relevant jurisdictions.**

**Key consideration 1: The legal basis should provide a high degree of certainty for each material aspect of an FMI's activities in all relevant jurisdictions.**

#### Material aspects and relevant jurisdictions

The DCV is a Chilean company and as such is organized and regulated based on Chilean legislation, as a "securities depository company" incorporated in accordance with Law 18.876 that regulates Private Securities Deposit and Custody Entities. Its legal organization corresponds to a Chilean corporation, so the provisions of Law 18.046 on Corporations are also applicable to it.

The important aspects of the CSD's activities that require a high degree of legal certainty are: (1) Immobilization, book-entry and dematerialization of securities, and (2) Protection of client assets, including the segregation of depositors' and their clients' positions.

#### Legal basis for each material aspect

The current legal framework provides a clear and effective basis for the application of procedures for the immobilization, dematerialization and transfer of securities, through book entries, through securities depository and custody companies. The rules governing the system and the contracts between its participants are legally enforceable even in the event of insolvency by one of the participants. Thus, Law 18.876 establishes provisions regarding the legal value of the deposit contract. Likewise, the law covers the relationship between the CSD and its depositors, its duties vis-à-vis them, and its internal governance.

With regard to the immobilization, book-entry and dematerialization of securities, Article 11 of Law No. 18,876 establishes book-entry rules in the event of immobilization or dematerialization of securities and their applicability.

In relation to the segregation and protection of assets, Article 4 of Law 18.876 establishes that they must be kept segregated, while Article 5 of the same law protects such assets from the insolvency of custodians and intermediaries.

**Key consideration 2: An FMI should have rules, procedures, and contracts that are clear, understandable, and consistent with relevant laws and regulations.**

The activities of the DCV are mainly regulated by Law 18,876 on "Private Entities for the Deposit and Custody of Securities" and by Supreme Decree 734 of the Ministry of Finance, which establishes additional regulations related to the operation of deposits (see General Context of the DCV). In addition, the company's Articles of Association regulate aspects of its legal constitution and some corporate governance topics. The main internal regulation of the DCV is the Internal Regulations, approved by the CMF, which are complemented by internal

circulars, policies and procedures. The DCV's Internal Regulations and internal circulars are publicly available through its website, while other documents are available only to its participants and can be found in the depositors section of the website.

The rules, procedures and contracts of DCV are clear and understandable. Since the last self-assessment in 2022, depositors have not asked the CSD for clarification or interpretation regarding any aspect of its regulations.

The procedures and contracts of the DCV have not been contested in any significant aspect by DCV participants, neither in front of the CMF or in judiciary instances. The DCV rules, procedures and contracts are revised by legal experts (internal and external). Moreover, the DCV's Rulebook is approved by the CMF as well as all changes to it. DCV's procedures are consistent with applicable laws and regulations.

No inconsistencies have been found in the procedures, rules and contracts used by the DCV. Laws and regulations provide guidance on the minimum contents of the contracts between the DCV and its participants (mainly the depositors of securities, but also the issuers of securities).

**Key consideration 3: An FMI should be able to articulate the legal basis for its activities to relevant authorities, participants, and, where relevant, participants' customers, in a clear and understandable way.**

The main rules and activities of the DCV are dealt with in the Internal Regulations of the DCV and certain aspects of the DCV are further developed in circulars. The DCV also publishes foreign DCV regulations and contracts signed with foreign custodians. The applicable laws are in the international custody contracts signed by investors with the DCV. All relevant documents are provided to all depositors of the DCV and are considered to be part of the contract and are therefore binding on all participants. The documents, as well as any updates, are also posted on the DCV website.

Prior to publication, changes to the internal regulations are subject to a consultation process. The organizations included in the consultation process are: shareholders, depositors, regulators and the other IMFs.

**Key consideration 4: An FMI should have rules, procedures, and contracts that are enforceable in all relevant jurisdictions. There should be a high degree of certainty that actions taken by the FMI under such rules and procedures will not be voided, reversed, or subject to stays.**

*Enforceability of rules, procedures and contracts*

DCV's Rulebook was approved by the CMF consistent with Laws 18,876 and 18,045, among others, and its provisions are therefore deemed fully enforceable for securities transactions undertaken in Chile.

The DCV commissions legal opinions regarding the enforceability of its rules and procedures about its foreign custody services – in particular, about providing deposit accounts for foreign CSDs. Based on this opinion, DCV does not have concerns regarding conflict-of-law issues or enforceability of its choice of law in relevant jurisdictions.

Degree of certainty for rules and procedures

All key rules and provisions in the Rulebook are based on laws (especially Law 18,876) and on rules issued by the CMF.

There is no precedent of a DCV rule or procedure being revoked by any other competent authority.

**Key consideration 5: An FMI conducting business in multiple jurisdictions should identify and mitigate the risks arising from any potential conflict of laws across jurisdictions.**

The DCV engages in foreign custody activities. For this purpose, DCV has links (i.e. holds accounts and vice versa) with CSDs in Mexico, Colombia and Peru, as well as DTCC in the United States and with Euroclear. The contracts that investors in Chile sign with the DCV for this purpose state that for transactions with securities held at foreign CSDs, the applicable law is that of the foreign CSD or foreign custodian.

The DCV maintains securities accounts with the CSDs of Mexico (Indeval), Colombia (Deceval) and Peru (Cavali), as well as with Citi in the United States and Euroclear in Belgium (see Principle 20). In the international custody service, through which the CSD holds the foreign securities of its depositors, the contracts that investors in Chile sign with the CSD for this purpose establish that, for transactions with securities held in foreign CSDs, the applicable law is that of the foreign CSD or foreign custodian.

## Principle 2: Governance

**An FMI should have governance arrangements that are clear and transparent, promote the safety and efficiency of the FMI, and support the stability of the broader financial system, other relevant public interest considerations, and the objectives of relevant stakeholders.**

**Key consideration 1: An FMI should have objectives that place a high priority on the safety and efficiency of the FMI and explicitly support financial stability and other relevant public interest considerations**

The mission of the DCV is "To provide the local and international capital markets, infrastructure and other complementary solutions, under the highest standards of transparency, security and efficiency". The DCV also manages its strategic objectives through a balanced scorecard, which reflects measurable objectives. Among those that are especially relevant to financial stability, operational quality can be highlighted, including reliability, uptime of its technological infrastructure, compliance with related service level agreements with FMIs, etc.

**Key consideration 2: An FMI should have documented governance arrangements that provide clear and direct lines of responsibility and accountability. These arrangements should be disclosed to owners, relevant authorities, participants, and, at a more general level, the public.**

### Governance arrangements

The DCV is constituted as a corporation in accordance with Law 18.046, so the regulations of Chilean corporations are applicable to it, including those matters of governance (or corporate governance, or good governance). Its main shareholders are national banks (30% ownership), pension fund managers (30%), the Santiago Stock Exchange (23%), insurance companies (10%), the Electronic Stock Exchange (6.4%) and other shareholders (0.4%). In addition, Law No. 18,876 on securities depository and custody companies establishes certain applicable rules on governance, such as the existence of a Surveillance Committee.

The DCV has adequate processes in place to ensure accountability to all its stakeholders (shareholders, regulators, depositors, and other users). The main accountability mechanism is the above-mentioned Supervisory Committee, whose members are elected by the CSD Depositors' Assembly. This committee reports exclusively to the Assembly on a regular basis and to the CMF when required.

### Disclosure of good governance mechanisms

The Articles of Association of the CSD company, which govern its main governance arrangements, are published on its website and the CSD discloses other governance arrangements through the internal regulations of internal circulars. All of the above are available on the DCV website, with the exception of the Articles of Association and minutes of the shareholders' meeting which are available only to depositors. In addition, there is also a "corporate governance" and "corporate information" section on the website with specific information on these topics.

**Key consideration 3: The roles and responsibilities of an FMI's board of directors (or equivalent) should be clearly specified, and there should be documented procedures for its functioning, including procedures to identify, address, and manage member conflicts of interest. The board should review both its overall performance and the performance of its individual board members regularly.**

The shareholders, at the shareholders' meeting, nominate DCV's board of directors, composed of 10 members, who serve for two years and can be re-elected indefinitely. The governance requirements of the DCV are mainly established in Law 18,045 on Corporations and Law 18,876 on securities depository and custody companies. The internal regulations of the DCV regarding governance are incorporated in the Statutes of the DCV, the Internal Regulations and specific policies.

The organization is governed by a board of directors, and a General Manager reporting directly to the board. Below the General Manager are nine managers. On the other hand, the Comptroller Manager reports to the board of directors. Every year, the DCV holds a shareholders general meeting to report on the activities carried out during the year. Among other functions, the shareholders meeting of appoints an external auditor.

#### Board Roles and Responsibilities

As a corporation, the responsibilities of the DCV board of directors include those established by Law 18,046 on Corporations. In addition, in accordance with the Internal Rules (section 2.1.1), the board of directors is responsible for the stability and safe operation of the DCV, as well as for the strict observance of the laws and regulations applicable to it. Among the main matters regulated by the Articles of Association of the DCV are the number, duration and re-election of board members and the quorums required for the approval of specific matters indicated in the Articles of Association. As far as the operation of the board is concerned, the DCV has a specific regulation in the Rules of Operation of the board.

#### Documented Procedures and Conflicts of Interest

The Conflicts of Interest Policy includes procedures for managing conflicts of interest by board members. For the purpose of dealing with a conflict of interest, the DCV's Related Party Operations Policy applies. For example, members with a potential or actual conflict of interest must inform the board of directors of this situation and if the board so determines, such members must abstain.

The board's detailed procedures are disclosed to shareholders and the CMF. On the other hand, only some of the more general procedures are disclosed to the general public.

#### Performance Review

Every year, the DCV implements a questionnaire focused on knowing the perception of board members regarding the practices and structure of the DCV board of directors, based on good industry practices and the corporate governance questionnaire that Chilean regulation establishes for public corporations. The questionnaire covers the vision both from the perspective of the functioning of the board and the performance and preparation of the board members.

**Key consideration 4: The board should contain suitable members with the appropriate skills and incentives to fulfill its multiple roles. This typically requires the inclusion of non-executive board member(s).**

The corporate governance of the DCV rests on a mutual-type ownership structure, under which users grouped into industries or market sectors have a stake in the ownership (and representation on the board) with some alignment with the intensity of use of the DCV's services. This configuration of corporate governance has contributed to the control of operating costs and to the stability and continuity of its board of directors.

Representation on the board usually parallels the ownership structure, i.e. different types of institutions (e.g. banks, exchanges, etc.) appoint one or more directors on the basis of their collective participation in the DCV. The DCV's board of directors is made up of professionals with extensive experience in the Chilean capital market, usually in the fields of industries represented in the DCV's ownership. Likewise, the members of the board of directors are also senior executives (current CEOs or presidents) of companies in the same sector. Board members are remunerated and entitled to an additional stipend for their participation as members of any of the board committees. No member of the board is an executive of the DCV.

**Key consideration 5: The roles and responsibilities of management should be clearly specified. An FMI's management should have the appropriate experience, a mix of skills, and the integrity necessary to discharge their responsibilities for the operation and risk management of the FMI.**

#### Roles and Responsibilities of Senior Management

The specific roles, responsibilities, and functions for each of the senior management are clearly defined in the internal documentation. Such documentation also sets forth the preferred professional background, minimum experience, and other desirable personal characteristics and attributes for each senior management position. The critical success factors and management indicators for each of the positions are also detailed in these documents.

#### Experience, Skills, and Integrity

The performance of the management team is evaluated using key performance indicators (KPIs), financial results, system uptime, and other variables. Critical success factors and management indicators have been specified for some of the senior management positions. The evaluation of senior management and other staff is conducted once a year. With respect to the removal of management, the company's Articles of Association specify that the General Manager may be removed by the vote of at least seven directors. There is a policy approved by the board of directors that sets out the internal guidelines for the process of disengagement and replacement of the general manager and senior executives of the DCV.

**Key consideration 6: The board should establish a clear, documented risk-management framework) that includes the FMI's risk-tolerance policy, assigns responsibilities and accountability for risk decisions, and addresses decision making in crises and emergencies. Governance arrangements should ensure that the risk-management and internal control functions have sufficient authority, independence, resources, and access to the board.**

#### Risk Management Framework

The DCV has developed a risk management framework, based on the ISO 31000 standard, and which main regulation is the Risk Management Policy, which establishes the general guidelines for risk management, as

well as the responsibilities of the different parties within the organization. In addition, the DCV has a Risk Management Model, which describes the procedures and controls for identifying, measuring, treating, supervising, and reviewing the risks faced by the organization. The Risk Management Policy covers all categories of risks to which the DCV is exposed, including operational, general business, custody, legal and reputational risk.

#### Authority and independence of audit and risk management functions

Risk management and internal control play an important role in the management of the board through two specific committees (risk and cybersecurity committee and audit committee). The Risk Manager has overall responsibility for risk management in the DCV, as well as regulatory compliance management functions. The Comptroller Manager is responsible for internal audit and reports to the board of directors. The main objectives of this management are to ensure that the organization has an audit plan that focuses on key risks and provides an independent opinion on the effectiveness of controls over all of the organization's operational processes. A financial audit and an operational audit are carried out annually, both of an external nature. In addition, there is a Supervisory Committee made up of depositors of the DCV (see "Overview of the CSD").

**Key consideration 7: The board should ensure that the FMI's design, rules, overall strategy, and major decisions reflect appropriately the legitimate interests of its direct and indirect participants and other relevant stakeholders. Major decisions should be clearly disclosed to relevant stakeholders and, where there is a broad market impact, the public.**

#### Identification and consideration of the interests of stakeholders

The shareholders who elect the board of directors of the DCV are companies owned by depositors grouped in capital market sectors. For example, one of the companies that owns the DCV is owned by most of the national banks, retains 30 per cent of ownership of the DCV, and has the same proportion of votes in the election of members of the board. A similar case occurs with pension fund administrators and life insurance companies, while the Santiago Stock Exchange and the Chilean Electronic Stock Exchange also maintain ownership of the DCV, and their shareholders are mostly stockbrokers. Depositors are represented on the board in a proportion reasonably aligned with their share of the intensity of use of DCV services, although this alignment is not formalized.

With regard to its direct relationship with the users of the system, the DCV holds an annual meeting of depositors and is responsible to the Supervisory Committee that represents the interests of depositors in certain aspects established in Law 18.876. The DCV also has developed a body called the "Depositors' Committee" under which the *development of DCV initiatives is presented. and depositors' opinions and concerns are raised.*

#### Disclosure

The decisions of the General Shareholders' Meeting are made known to the public through the DCV website. Other important decisions of the board are made known to participants through newsletters or emails and are finally implemented through circulars that are publicly available on the DCV website.

### Principle 3: Framework for the Comprehensive Management of Risks

An FMI should have a sound risk-management framework for comprehensively managing legal, credit, liquidity, operational, and other risks.

**Key consideration 1: An FMI should have risk-management policies, procedures, and systems that enable it to identify, measure, monitor, and manage the range of risks that arise in or are borne by the FMI. Risk-management frameworks should be subject to periodic review.**

#### *Risks arising at or assumed by the FMI*

As a CSD, DCV is exposed to operational, general business, custody, legal and reputational risk. More information on the management of the different types of risk can be found in the respective descriptions of principles 15, 16 and 17. At the same time, the DCV exposes its participants and other FMIs primarily to operational risk.

#### *Risk Management Policies, Procedures and Systems*

As indicated in the description of Principle 2, the DCV has developed a risk management framework, based on the ISO 31000 standard, the main regulation of which is the Risk Management Policy, which describes the objectives, scope and key processes, as well as the lines of responsibility and accountability with respect to risk management and decision-making. Lines of responsibility include process owners, risk and compliance management, audit management, and the board of directors.

In addition, the DCV has a Risk Management Model, which describes the procedures and controls for identifying, measuring, treating, supervising, and reviewing the risks faced by the organization. The Risk Management Policy covers all categories of risks to which the DCV is exposed, including operational, general business, custody, legal and reputational risk.

The DCV identifies specific risks through process and procedure analysis, feedback from its participants, and internal and external audits. Specialized risk management software is used to monitor and manage identified risks. Internal electronic controls report on key processes on a daily basis.

The DCV accepts risks that are equivalent to or less than the "moderate risk" (the maximum impact level has a remote probability of materializing). The Risk Management Policy is approved by the Board of Directors, including any subsequent changes.

#### *Review of risk management policies, procedures and systems*

Risk management is based on those responsible for and executing the processes, who are the primary risk managers; risk and compliance management, which is responsible for risk management and monitoring; The Board of Directors and the Management Committees approve and monitor the performance of the Risk Management Model and the Audit Management is responsible for evaluating the effectiveness of the implementation of the Risk Policies.

Proposals for improvement come from a range of feedback mechanisms, such as internal and external audits, interactions with depositors and other FMIs, or observations from regulators, mainly the CMF. The people responsible for verifying the risk controls are: the head of the respective area, the Risk Manager and the General Manager.

The DCV has a balanced scorecard and a series of specific KPIs to assess the effectiveness of its policies, procedures and systems, including risk management aspects. The external auditor also annually reviews the risk control mechanism and aspects associated with the custody and transfer of securities, which are also reviewed by the Surveillance Committee.

The Risk Management Policy is approved by the board of directors, including any subsequent changes. The policy establishes that senior management must ensure that at least once a year, the review of the risk management system is carried out, to ensure its continuous improvement, compliance and effectiveness to meet the requirements of the international standards used as a reference, and of the risk management policies and objectives established for the CSD. keeping track of such reviews (e.g., through audits, self-assessments, compliance verification, incident monitoring, and risk matrices).

Since 2009, the DCV has presented the independent report SSAE-18, prepared and evaluated by an external auditing firm and which verifies the internal control structure of the DCV, as an organization that provides services to third parties, with emphasis on the processes that affect the internal control structure of the user organization.

During November 2022, the DCV obtained the recertification of its internal audit process by the Institute of Internal Auditors of Spain authorized by the Global Institute of Internal Auditors (IIA Global), the highest global authority on the matter.

**Key consideration 2: An FMI should provide incentives to participants and, where relevant, their customers to manage and contain the risks they pose to the FMI.**

The DCV provides depositors with training on the systems it operates and any changes to those systems are communicated in a timely manner. Online information regarding the settlement process of transfer instructions entered by depositors is available to depositors.

According to the Internal Regulations, depositors must assume responsibility for the due care and proper use of user profiles and credentials. Likewise, sanctions are established for non-compliance with any internal regulations of the DCV. Such sanctions include written reprimands, fines, suspension or expulsion.

The DCV's Customer Service Desk (MAC) identifies depositors' operational deficiencies or errors and identifies when the need arises to retrain a specific operator or develop additional training needs.

**Key consideration 3: An FMI should regularly review the material risks it bears from and poses to other entities (such as other FMIs, settlement banks, liquidity providers, and service providers) as a result of interdependencies and develop appropriate risk-management tools to address these risks.**

### Material risks

The identification of risks and their factors is carried out by those responsible for the processes, sub-processes, assets or any other element evaluated within the risk management model, being advised by the risk and compliance management and the audit management. To this end, the processes are documented through flowcharts and narratives and a series of techniques are used that can be used to carry out risk identification, assessment and treatment activities. Those responsible must indicate their name; description; owner; current/expected frequency; current/potential magnitude; current/potential business impact; elimination; among other subjects.

With respect to risks originating in other FMIs, for securities custody and transfer services, the DCV may be exposed to reputational risk in the event that other interconnected FMIs experience operational problems, as they may not be able to provide those services efficiently and reliably.

With respect to its other services in its securities depository (CSD) function, the DCV is also exposed to risks in the administration of securities. In addition, the securities transfer service that the DCV makes available to its depositors jointly with ComBanc (which involves a connection to the Central Bank's RTGS System) could be affected by a failure of either of these two FMIs.

The CSD does not face risks from settlement banks or liquidity providers. The DCV exposes other FMIs to operational risks, including, in particular, ComDer and CCLV (both as CCPs and the latter also as SSS) and the BCRS system of the Central Bank of Chile. Those other IMFs may not operate normally in the event that the CSD experiences a failure: the RTGS system, ComDer and CCLV would not be able to carry out their collateral administration activities. In addition, CCLV would not be able to transfer ownership of securities for its activities as SSS and as CCP.

### Risk management tools

The Risk Management Model establishes the guidelines and processes according to which the macro risk management process must be managed. The technological tool used in risk management is the OpenPages governance, risk and compliance (GRC) platform developed by IBM.

The DCV monitors these risks on an ongoing basis and reviews risk management tools once a year. To manage the risks it poses to other FMIs, the DCV has participated in a series of bilateral trade continuity tests. The DCV is also a participant of the business continuity committee that is led by the Central Bank of Chile and brings together other FMIs such as the RTGS system, ComBanc, CCLV, etc.

**Key consideration 4: An FMI should identify scenarios that may potentially prevent it from being able to provide its critical operations and services as a going concern and assess the effectiveness of a full range of options for recovery or orderly wind-down. An FMI should prepare appropriate plans for its recovery or orderly wind-down based on the results of that assessment. Where applicable, an FMI should also provide relevant authorities with the information needed for purposes of resolution planning.**

### *Scenarios that may prevent an FMI from providing critical operations and services*

The DCV has a Business Continuity Management System Policy, which provides the framework to identify risk

scenarios that may affect the DCV and minimize the likelihood of failure of critical operations and services. The scenarios identified mainly include the materialization of one or more of the following risks: fires, floods, earthquakes, terrorist attacks, fraud and theft, social upheaval, and war and violent conflict. In addition, the Business Risk Management Framework contemplates scenarios associated with the loss of financial continuity of the DCV (see description of Principle 15).

*Recovery or orderly wind-down plans*

Through its Business Continuity Plan (BCP), the DCV has defined recovery strategies for its critical business units within a defined timeframe, based on the business impact analysis (BIA). The focus of this plan is the recovery of disruptions caused by the materialization of operational risks. Although the DCV does not have an orderly liquidation plan, Articles 37 to 46 of Law 18,876 provide for an orderly liquidation procedure for CSDs in Chile.

## Principle 10: Physical Deliveries

**An FMI should clearly state its obligations with respect to the delivery of physical instruments or commodities and should identify, monitor, and manage the risks associated with such physical deliveries.**

**Key consideration 1: An FMI's rules should clearly state its obligations with respect to the delivery of physical instruments or commodities.**

The DCV holds a small volume of physical securities from its depositors, which represent 0.9% of the total amount of securities deposited as of the date of this report. These securities relate mainly to some corporate bonds and fixed-term deposits. The General Rule 77 of the CMF establishes that depositors may request withdrawals and physical issuance of securities that have been issued in the event of an increase in the DCV fees for services or the implementation of new remunerated services whose use is mandatory for the depositor.

Responsibilities with respect to the delivery of physical instruments are established in Law 18,876 and in the regulations of the CMF. The procedure for withdrawing physical securities is defined in section 10.9.1 of the Internal Rules. The liability of the DCV is limited to delivering the value in physical form to the owner (or his representative). The DCV engages with its depositors through regular training sessions, circulars and newsletters to ensure that they have a clear understanding of their obligations and the procedures for effecting the physical delivery of securities.

**Key consideration 2: An FMI should identify, monitor, and manage the risks and costs associated with the storage and delivery of physical instruments or commodities.**

The risks associated with the storage and delivery of physical instruments are identified in the DCV's risk matrix i.e. physical custody and physical delivery are two of the processes identified in the BIA. The principal risks identified as operational, reputational and information security. The cost identified in relation to the storage and delivery of physical securities is considered significant by the Company, representing over 1% of total monthly expenses. Section 10.2.6 of the Rulebook specifies the processes, procedures and controls to monitor and manage these risks. Physical securities received by DCV are stored in vaults and must be kept following a pre-determined system to ensure easy access and identification. In this context, the DCV has implemented security systems to prevent theft, fires and other potential events that could cause destruction of the physical securities. In addition, the DCV has also implemented microfilm, electronic records and other similar mechanisms to, in case it becomes necessary, ensure proper reconstitution of the physical securities.

Additionally, DCV performs daily reconciliations of positions with physical securities with participants / issuers; there is separation of duties between handling physical securities and record-keeping; access restrictions to vaults and areas where physical securities are located.

DCV can match receipt and delivery instructions of transactions related to physical securities. DCV does not perform surveillance to verify that its depositors have the necessary systems and resources to be able to fulfil their own physical delivery obligations.

## Principle 11: Central Securities Depositories

**A CSD should have appropriate rules and procedures to help ensure the integrity of securities issues and minimize and manage the risks associated with the safekeeping and transfer of securities. A CSD should maintain securities in an immobilized or dematerialized form for their transfer by book entry.**

**Key consideration 1: A CSD should have appropriate rules, procedures, and controls, including robust accounting practices, to safeguard the rights of securities issuers and holders, prevent the unauthorized creation or deletion of securities, and conduct periodic and at least daily reconciliation of securities issues it maintains.**

The DCV operates a system of indirect securities accounts, partly as a result of the Law 18,876, which grants depositor status only to certain legal entities, such as institutional investors, banks, issuers of securities, and securities intermediaries. Since non-institutional investors are generally not legally qualified to become depositors, they must do so through a legal entity authorized to be depositors and that also provides securities custody services, usually securities intermediaries and banks.

### *Safeguarding the rights of issuers and holders*

According to Article 5 of Law 18,876 in the relations between the DCV and the depositor, the depositor is the owner of the securities. On the contrary, in the eyes of the issuer and third parties, the CSD is considered the owner. However, the same article clarifies that this consideration of the CSD as the owner "does not mean that the depositor or its customer, as the case may be, ceases to have ownership on the securities deposited, for the exercise of political and economic rights".

From the perspective of a non-institutional investor, this must custody the securities through a depositor who provides the securities custody service which, as previously indicated, usually corresponds to a securities intermediary or a bank.

Regulations, procedures, internal controls, and technology systems safeguard the rights of securities issuers and holders. The securities holding records in the DCV are separate from the DCV participants themselves. The securities of depositors acting as custodians are separated from the securities of their customers, either through omnibus accounts or individual accounts.

In the case of custody agreements whereby the DCV acts as a direct participant with the foreign CSDs or custodians (Citi, Euroclear, and the CSDs of Colombia, Mexico and Peru), it is specified that all securities held as part of the custody agreements belong to the respective clients of the DCV.

The DCV administers the outstanding securities until they are fully amortized or mature, at which point the securities are automatically deleted from the system. Both the internal and external audit review team annually review the procedures and controls used for custody. The supervisory committee representing depositors also conducts a reconciliation procedure every quarter to ensure that there are sufficient securities to meet the rights of each of the DCV depositors.

Prevention of the unauthorized creation or deletion of securities

The issuer is required to provide the DCV with an authorization to create securities. This document must be signed by the issuer's authorized personnel (persons with power of attorney are registered with the DCV). This document is reviewed by the legal department of the DCV. Only after these steps have been successfully completed, the issuance amount can be loaded into the DCV system.

Periodic reconciliation of securities issues

The outstanding balance of all issuances is checked daily with issuers. In the case of shares, this is verified with shareholder records. Through these controls, along with internal audits and external audits, it is ensured that no values are improperly created or deleted. The DCV also reconciles the balances of the securities accounts it maintains with other CSDs and foreign custodians.

**Key consideration 2: A CSD should prohibit overdrafts and debit balances in securities accounts.**

Securities transfers can only be processed if there are sufficient securities in the corresponding securities depository accounts. Likewise, the DCV does not allow overdrafts or debit balances for any type of transfer orders (e.g. transfer of securities conditional on the transfer of other securities).

**Key consideration 3: A CSD should maintain securities in an immobilized or dematerialized form for their transfer by book entry. Where appropriate, a CSD should provide incentives to immobilize or dematerialize securities.**

As indicated in principle 10, as of the date of this evaluation, of all the securities held in the DCV, 99.1% of the total amount in pesos is in dematerialized form and the rest in physical form. On the other hand, approximately 99% of the total volume of transactions are carried out on securities held in dematerialized form. For securities that are still held in physical form, it is possible to freeze them and allow them to be held and transferred in a book-entry system (Article 7.2.2. of the Internal Rules). The higher fees applicable to the deposit of physical securities constitute an incentive set by the DCV for the immobilization and dematerialization of securities.

**Key consideration 4: A CSD should protect assets against custody risk through appropriate rules and procedures consistent with its legal framework.**

Article 27 of Law 18,876 states the responsibilities of the DCV regarding custody risk. DCV rules (Article 2.2.1 of the Rulebook) states provisions to protect depositors against custody risk in case of the following events: negligence, misuse of assets, fraud, poor administration, inadequate recordkeeping, authenticity and integrity of securities held under custody, etc. The rules and procedures related to custody risk are consistent with the applicable legal and regulatory framework. Apart from rigorous internal controls and internal and external supervision mechanisms, DCV has insurance policies to protect its depositors against misappropriation, destruction and theft of securities. These policies pay up to 0.1% of the total quantity under custody.

**Key consideration 5: A CSD should employ a robust system that ensures segregation between the CSD's own assets and the securities of its participants and segregation among the securities of participants. Where supported by the legal framework, the CSD should also support operationally the segregation of securities belonging to a participant's customers on the participant's books and facilitate the transfer of customer holdings.**

The DCV allows for the existence of segregated accounts from those of depositors and their clients and are used at the discretion of depositors in accordance with applicable regulations or their third-party custody practices.

When depositors maintain separate accounts for the purpose of custody of third-party securities, they create their own portfolio account ("Own Securities Account"), as well as segregated accounts called "Third-Party Securities Accounts". In the latter case, there are two types of accounts: at the omnibus level ("Grouped Customers Account"), and at the depositor's client level ("Individual Customer Account").

According to Article 179 of Law 18,045 on the Securities Market, stockbrokers are required to maintain separate omnibus accounts and offer custody services in individual accounts for optional use by clients, while in the case of banks and other financial institutions that act as depositors, the use of segregated accounts is optional although frequent.

Article 19 of Law 18,876 establishes that CSDs may hold their own securities. These holdings should be individualized in their accounting systems to ensure that they can be clearly distinguished from depositors' securities.

**Key consideration 6: A CSD should identify, measure, monitor, and manage its risks from other activities that it may perform; additional tools may be necessary in order to address these risks.**

The company "DCV Asesorías y Servicios" was created in 2020 to address the development and implementation of new services, as well as for this entity to provide some services that to date are offered directly by the DCV. Through DCV Asesorías y Servicios, the DCV offers the following services: 1) DTCC Transaction Comparison Service, which allows validating transactions with foreign investors; 2) Statistical Reports, which provide statistical information to the market; 3) Administration of Active Affiliate Recognition Bonds (BRAA), which provides value-added services on BRAAs, and 4) Responsible Tax Agent, which performs tax representation activities for foreign investors. In addition, the DCV itself offers the service of registration of forward contracts and Omgeo, which provides information services during the post-trade and pre-settlement processes of investment fund quotas. The activities are detailed in the Internal Rules.

The risks identified in these activities are essentially operational risks. Such risks are managed as part of the operational risk management policy of the DCV in accordance with the requirements of Circular 1,939 of 2005 of the CMF ("Instructions on the implementation of operational risk management in securities depository and custody institutions and in the management companies of clearing and settlement systems for financial instruments").

### **Principle 13: Participant-Default Rules and Procedures**

**An FMI should have effective and clearly defined rules and procedures to manage a participant default. These rules and procedures should be designed to ensure that the FMI can take timely action to contain losses and liquidity pressures and continue to meet its obligations.**

**Key consideration 1: An FMI should have default rules and procedures that enable the FMI to continue to meet its obligations in the event of a participant default and that address the replenishment of resources following a default.**

The DCV acts as a CSD, and also participates in the management of the DVP process in the gross settlement system, in conjunction with the ComBanc Switch; CCLV provides net settlement services as SSS and CCP. Accordingly, in its role as a CSD, the DCV acts solely on the basis of the instructions received and assumes no liability for any non-compliance associated with the delay or non-delivery of securities and/or funds associated with the settlement of securities. In the case of the gross settlement process carried out with the ComBanc Switch, there is no single operator responsible for the system. On this basis, principle 13 is considered to be inapplicable to CSDs.

**Key consideration 2: An FMI should be well prepared to implement its default rules and procedures, including any appropriate discretionary procedures provided for in its rules.**

As per KC 13.1, this principle is deemed to be not applicable to DCV.

**Key consideration 3: An FMI should publicly disclose key aspects of its default rules and procedures.**

As per KC 13.1, this principle is deemed to be not applicable to DCV.

**Key consideration 4: An FMI should involve its participants and other stakeholders in the testing and review of the FMI's default procedures, including any close-out procedures. Such testing and review should be conducted at least annually or following material changes to the rules and procedures to ensure that they are practical and effective.**

As per KC 13.1, this principle is deemed to be not applicable to DCV.

## Principle 15: General Business Risk

**An FMI should identify, monitor, and manage its general business risk and hold sufficient liquid net assets funded by equity to cover potential general business losses so that it can continue operations and services as a going concern if those losses materialize. Further, liquid net assets should at all times be sufficient to ensure a recovery or orderly wind-down of critical operations and services.**

**Key consideration 1: An FMI should have robust management and control systems to identify, monitor, and manage general business risks, including losses from poor execution of business strategy, negative cash flows, or unexpected and excessively large operating expenses.**

There is a General Business Risk Policy that establishes at a high level the general business risk management framework which is led by the risk and compliance management, with the participation of the finance and control management. Additionally, the "General Business Loss Management Protocol" establishes the processes and activities necessary for the correct management, governance and monitoring of general business. In this context, the CSD has developed the modelling of general business risk, including the identification of general business risk factors, and the respective assigned controls and their documentation. To this end, two sources of risk have been identified by grouping the risk factors that may involve general business losses and thus affect the company's operation: a) Specific scenarios, which consider particular, unanticipated events that require a flow of resources with sufficient liquidity to take mitigation measures (deficient execution of business strategy, internal and external fraud, etc.) and, b) Structural scenarios, which refer mainly to scenarios that affect or generate a permanent increase in costs or a significant decrease in revenues and that have an impact of 20% with respect to the Ebitda/Sales indicator (loss of key customers, decrease in transactions, etc.). A risk matrix assigns probabilities to each scenario and establishes the respective controls to address each risk.

**Key consideration 2: An FMI should hold liquid net assets funded by equity (such as common stock, disclosed reserves, or other retained earnings) so that it can continue operations and services as a going concern if it incurs general business losses. The amount of liquid net assets funded by equity an FMI should hold should be determined by its general business risk profile and the length of time required to achieve a recovery or orderly wind-down, as appropriate, of its critical operations and services if such action is taken.**

The "General Business Loss Management Protocol" defines the requirement to maintain a "General Business Loss Fund", as well as its calculation methodology and monitoring. This fund is intended to cover potential general business losses so that the DCV can continue to operate and provide services if such losses materialize, for the determination of an orderly recovery or liquidation fund. The fund essentially corresponds to the difference between the current assets and liabilities of the DCV. According to the document "Procedure: DCV General Business Loss Fund", the amount of the fund thus determined must be equivalent to the resources necessary to cover the expenses corresponding to 6 months of operations. To determine these resources, a forward-looking approach is used, by a 12-month projection of the net liquid assets of the DCV, simulating the impact of the following scenarios: increase in costs, decrease in revenues, as well as both effects at the same time, in order to ensure that such net liquid assets are permanently at least he mentioned 6 months of operation

As of December 31, 2023, the amount of total liquid net assets, defined in accordance with the explained procedure, amounted to approximately \$15 million, equivalent to 10 months of operating expenses. At the same date, minimum total net liquid assets (6 months of operations) amounted to approximately \$9.4 million.

**Key consideration 3: An FMI should maintain a viable recovery or orderly wind-down plan and should hold sufficient liquid net assets funded by equity to implement this plan. At a minimum, an FMI should hold liquid net assets funded by equity equal to at least six months of current operating expenses. These assets are in addition to resources held to cover participant defaults or other risks covered under the financial resources principles. However, equity held under international risk-based capital standards can be included where relevant and appropriate to avoid duplicate capital requirements.**

Recovery or orderly wind-down plan

The DCV's financial recovery plan is based on a procedure to raise additional capital that allows the DCV to be activate it when the minimum equity is reduced below the legal minimum capital (see fundamental consideration 5). The Law 18,876 establishes a mechanism for the orderly liquidation of the CSD.

Resources

As indicated in key consideration 3, according to the "Procedure: DCV General Business Loss Fund", the amount of the fund must be equivalent to the net liquid assets sufficient to cover the corresponding expenses of 6 months of operations.

**Key consideration 4: Assets held to cover general business risk should be of high quality and sufficiently liquid in order to allow the FMI to meet its current and projected operating expenses under a range of scenarios, including in adverse market conditions.**

The net liquid assets of the CSD are made up of the same financial assets contemplated in the current Investment Policy, these are concentrated in low-risk and highly liquid fixed-income instruments (see description Principle 16). These assets are managed by an entity defined in the Investment Policy as a "Portfolio Management Company", which must be a bank or bank subsidiary.

**Key consideration 5: An FMI should maintain a viable plan for raising additional equity should its equity fall close to or below the amount needed. This plan should be approved by the board of directors and updated regularly.**

Articles 36 and 37 of Law 18,876 provide for a procedure for the DCV recovery with respect to its minimum legal assets of UF 30,000 (approximately US\$1.1 million). Articles 41 to 46 of the same law establish a procedure for the orderly liquidation of securities depository and custody companies.

The DCV has developed a procedure to raise additional capital, which essentially replicates the provisions of Articles 36 and 37 of Law 18,876, i.e., that 30 business days after the deficit occurred without having exceeded it, the board of directors convenes an extraordinary shareholders' meeting to raise capital, which must be held within 60 business days following the occurrence of the deficit. If the capital increase is approved, it must be notified within a period of no more than 30 business days from the date of the agreement. If the capital increase is not achieved within this period, the CMF revokes the authorization to exist, beginning the process of orderly liquidation. The aforementioned procedure also establishes the responsibility of controlling and reporting compliance with the minimum equity to the finance management and management control.

Due to the ownership structure of the CSD, in which depositors are also shareholders, it is likely that shareholders will have an incentive to provide additional capital considering the essentiality of the DCV to their business continuity.

## Principle 16. Custody and Investment Risks

An FMI should safeguard its own and its participants' assets and minimize the risk of loss on and delay in access to these assets. An FMI's investments should be in instruments with minimal credit, market, and liquidity risks.

**Key consideration 1: An FMI should hold its own and its participants' assets at supervised and regulated entities that have robust accounting practices, safekeeping procedures, and internal controls that fully protect these assets.**

The DCV's Investment Policy, approved and reviewed annually by the board of directors, states that DCV's proprietary securities, typically term deposits, are held in its own deposit system in its own account. Any physical value must be held on the DCV's own premises, albeit in a separate vault from that used for customers' physical securities. According to the same Policy, cash investments must be held in national banks to a customer account in which the CSD is the beneficiary.

The DCV holds securities on behalf of its depositors as part of its foreign securities custody services, including in the central depositories of the Pacific Alliance countries, Citi and Euroclear. For this purpose, the DCV is a direct participant in these CSDs.

**Key consideration 2: An FMI should have prompt access to its assets and the assets provided by participants, when required.**

The DCV does not maintain guarantees on behalf of its participants and manages its own resources by contracting an entity defined in the Investment Policy as a "Portfolio Management Company", which must be a bank or bank subsidiary. The DCV has immediate access to the securities it holds in its own system. Similarly, you have immediate access to your bank accounts.

With respect to the assets it holds on behalf of third parties in CSDs and foreign custodians, as indicated, the DCV is a direct participant in the foreign CSDs and, as indicated in the respective contracts, is subject to the same rules as the other participants.

**Key consideration 3: An FMI should evaluate and understand its exposures to its custodian banks, taking into account the full scope of its relationships with each.**

The DCV holds current accounts in numerous banks, and some of its portfolio investments are also managed by banks. There are no other financial exposures with banks as these only play the role of depositors or securities issuers vis-à-vis the DCV.

**Key consideration 4: An FMI's investment strategy should be consistent with its overall risk-management strategy and fully disclosed to its participants, and investments should be secured by, or be claims on, high-quality obligors. These investments should allow for quick liquidation with little, if any, adverse price effect.**

### Investment strategy

As previously indicated, for the management of the DCV's resources, the company hires a "Portfolio Management Company" that manages the financial assets of the DCV at its discretion within the framework of the Investment Policy. In this sense, the permitted investments refer to fixed income instruments, mainly short-term, with a high-risk rating and high liquidity.

### Risk characteristics of investments

In its Investment Policy, the DCV indicates that for investments with own resources, only financial instruments that are consistent with the company's risk profile should be used; that enable the company to obtain a reasonably stable return on surplus liquidity and its long-term assets, and that enable the company to manage its financial resources in accordance with its operational needs.

The Investment Policy establishes that you can invest in shares of mutual funds, time deposits or other types of instruments issued with the backing of companies, banking or non-banking institutions and the state of Chile. With regard to the quality of debtors, it is established that all instruments must have a credit rating of BBB+ or higher.

It also includes maximum limits on investment in securities or issuers rated A-/AA (30%) and BBB+ (15%). Other limits are set based on the size of the liquid funds that the company has at its disposal to make investments Financial. These limits refer to the type of instruments, their duration, and diversification.

## Principle 17: Operational Risk

**An FMI should identify the plausible sources of operational risk, both internal and external, and mitigate their impact through the use of appropriate systems, policies, procedures, and controls. Systems should be designed to ensure a high degree of security and operational reliability and should have adequate, scalable capacity. Business continuity management should aim for timely recovery of operations and fulfillment of the FMI's obligations, including in the event of a wide-scale or major disruption.**

**Key consideration 1: An FMI should establish a robust operational risk-management framework with appropriate systems, policies, procedures, and controls to identify, monitor, and manage operational risks.**

### Identification of operational risk

As indicated in the description of Principle 2, the DCV has developed a framework for risk management, based on the ISO 31000 standard, which regulates the procedures and controls for identifying, measuring, addressing, monitoring and reviewing the risks faced by the organization. This framework is mainly formalized in the Risk Management Policy, which covers all DCV risks, including operational, general business, custody, legal and reputational risk. The policy defines operational risk as "the risk that deficiencies in internal information systems or processes, human error, management failures, or disruptions caused by external events will lead to the reduction, deterioration, or interruption of the services provided by the company."

The risk matrix developed by the DCV is designed and executed based on the DCV Risk Management Model, detailing the different risks and risk factors associated with operational risk, including technological risk, information continuity risk and information systems risk. Likewise, the risk management of the DCV complies with the provisions of CMF Circular 1939 on operational risk management. A GRC platform is used to monitor and manage the identified risks. Electronically implemented internal controls report on key processes on a daily basis.

### Operational Risk Management

The Risk Management Policy outlines the objectives, scope and key processes covered by the risk management framework, as well as the lines of responsibility and accountability for risk management and decision-making.

### Policies, Processes, and Controls

In addition to the Risk Management Policy, the DCV has developed policies for the various sources of operational risks, particularly in the area of technology, such as the Information Security Policy, the IT Infrastructure Use Policy, the Human Resources Policy, or the Software Quality Assurance Policy. The identification of potential sources of operational risk is integrated into the detailed activities and systems, and is part of the overall strategic planning of the DCV.

With regard to human resources, the DCV Human Resources Policy covers topics such as staff selection criteria, initial and in-service staff training, and promotion so that people are satisfied with their overall professional development, in order to reduce staff turnover. Individual work and teamwork are evaluated.

All applicants must pass the screening tests and controls. The Policy also emphasizes avoiding conflicts of interest and situations that may lead to weak controls or potential fraud.

With respect to change management, when the DCV is implementing software changes, updates, code improvements, and/or bug fixes, specific procedures are followed in order to ensure that no interruption in service arises as a result of the changes made. Procedures based on international standards and formalized in policies, such as the Software Development Policy, guide the development and renewal of systems and risk assessment for new technological projects.

As indicated in the description of Principle 11, in addition to internal controls and internal and external oversight mechanisms, the DCV has insurance policies in place to protect its depositors against misappropriation, destruction and theft of securities. These policies pay up to 0.1% of the total deposit amount. The areas covered by the risk policy include personnel, third-party relations (e.g., through contractual relationships), processes, IT and technology, and external risks and dependencies.

**Key consideration 2: An FMI's board of directors should clearly define the roles and responsibilities for addressing operational risk and should endorse the FMI's operational risk-management framework. Systems, operational policies, procedures, and controls should be reviewed, audited, and tested periodically and after significant changes.**

#### Roles, responsibilities and framework

Risk management and internal control play an important role in the management of the board through two specific committees (risk and cybersecurity committee and audit committee). The risk and compliance manager has overall responsibility for risk management in DCVs, as well as regulatory compliance management. The audit manager is responsible for internal audit and reports to the board. Lines of responsibility include process owners, risk management, senior management, the risk and cybersecurity committee, and the board of directors, complemented by audit management.

Specific responsibilities and roles are outlined in the Risk Management Policy, which is approved by the board, including any changes thereafter. According to the Policy, senior management must ensure that the risk management framework is reviewed at least once a year.

#### Review, Audit, and Verification

Audit management is responsible for internal audit processes, the scope of which includes the availability of information regarding risk management and compliance with the Organizational processes, procedures and practices, proposing corrective and preventive action plans from the point of view of efficiency, use of resources, fraud prevention and compliance with the current regulatory framework. The internal audit team reviews critical processes and procedures, and controls risks in key areas once every six months or less, and non-critical once every two years.

As indicated in the description of Principle 3, since 2009 the DCV has submitted the independent report SSAE-18, prepared and evaluated by an external auditing firm and which verifies the internal control structure of the DCV, as an organization that provides services to third parties, with emphasis on the processes that affect the internal control structure of the user organization. The Type II report certifies the controls put in place

and the evidence on the operational effectiveness of those controls. The controls are tested for a specific period, not less than 11 months, so it is possible to conclude with reasonable certainty whether they have worked properly during that period.

**Key consideration 3: An FMI should have clearly defined operational reliability objectives and should have policies in place that are designed to achieve those objectives.**

The reliability objectives set by the management team are disclosed to the board, the regulator and the internal and external auditors. These targets are reviewed once a year and DCV publishes its operational reliability targets in its annual report.

In the balanced scorecard, through which corporate objectives are measured, the following objectives linked to operational reliability have been defined:

98.8% or more of the cases the response time of applications less than 2 seconds.

99.80% or more compliance with service level agreements (SLAs) with the Central Bank.

99.97% or more of IT platform uptime.

98.50% or more SLA compliance with CCLV (2 agreed SLAs).

**Key consideration 4: An FMI should ensure that it has scalable capacity adequate to handle increasing stress volumes and to achieve its service-level objectives.**

The DCV has an IT Infrastructure Use Policy whose scope includes the management of technological resources, processing times, current business volumes, and the impact of new services.

The policy states that, on average, the use of installed capacity should not exceed 35%. In the case of batching, the policy dictates that the installed capacity should be sufficient to allow for full batch processing at least twice in the allotted time period. With respect to other systems (e.g., those that do not directly affect customer operations), usage should not exceed 60-70% of installed capacity. Capacity utilization is assessed on a monthly basis by the DCV.

The DCV tests the capability of its systems by simulating market stress conditions. This is done at least once a year. The results of the systems capability test are reported to the management team, the external auditor, the internal auditor, and the board.

It should be noted that the current processing capacity is 5 times higher than the pre-year 2022 capacity put into production. The DCV is carrying out studies to adapt the aforementioned Capacity Policy.

**Key consideration 5: An FMI should have comprehensive physical and information security policies that address all potential vulnerabilities and threats.**

### Physical Security

Security plans include procedures to prevent, mitigate, contain, and/or manage fires, floods, earthquakes, terrorist attacks, fraud and theft, social upheaval, and war and violent conflict. The safety plan is approved by the board and reviewed once a year.

The measures the DCV uses to limit people's physical access to its computer systems and physical securities include the use of building security, guards, and ID cards. In order to protect equipment and premises from fire, flood or natural disasters, the DCV has vaults, earthquake-resistant construction, gas-based fire suppression system, fire extinguishers, water sprinklers, etc.

### Information Security

The main source of information security regulation in the DCV is the General Information Security Policy, which is complemented by internal procedures and monitoring of standards that, as a whole, contribute to maintaining the confidentiality, integrity and availability of information, provide protection against potential threats and allow for the response and containment of information security incidents in a controlled manner.

The DCV conducts a security penetration test once a year. The results of this test are analyzed by IT Operations and Cybersecurity management, the management team, and the IT and Operational Efficiency Committee and the board of directors.

Logical security measures applicable to DCV staff members include individual usernames and passwords, role-based limitations, and remote access limitations. In terms of comprehensive IT security measures, the DCV has malware, anti-malware and anti-virus applications, intrusion detection systems, etc.

During the month of September 2022, the DCV successfully achieved recertification in the ISO 27001 standard on Information Security. This is the main international standard on this subject and reviews in a complementary and specific way 114 internal controls that seek to protect and preserve the confidentiality, integrity and availability of information from a wide range of threats. Certification to ISO 27001 is valid for three years, but considers revisions every year.

IT security policies are reflected in the DCV's overall information security policy, while physical security policies are reflected in the business continuity policy.

**Key consideration 6: An FMI should have a business continuity plan that addresses events posing a significant risk of disrupting operations, including events that could cause a wide-scale or major disruption. The plan should incorporate the use of a secondary site and should be designed to ensure that critical information technology (IT) systems can resume operations within two hours following disruptive events. The plan should be designed to enable the FMI to complete settlement by the end of the day of the disruption, even in case of extreme circumstances. The FMI should regularly test these arrangements.**

### Objectives of the service continuity plan

The main guideline of the DCV in terms of business continuity is the documented Business Continuity Management System Policy and a disaster recovery plan. The objective of the plan is to maintain service and

quality levels, and to minimize any negative impact in the event of disruption to the operation of the company.

#### Design of the business continuity plan

During the month of September 2022, the DCV obtained international recertification in the ISO 22301:2012 standard "Security of the company – Business continuity management systems – Requirements", developed by the British Standards Institution (BSI). ISO 22301 is an international standard for business continuity management, identifying the fundamentals, establishing the process, principles and terminology of business continuity management. It provides a foundation for understanding, developing, and implementing business continuity within your organization.

Likewise, in the context of the SSAE-18 audit, since 2017 the DCV has submitted the AT-205 report, prepared and evaluated by an external audit firm. AT-205 is an independent report on the internal control structure of the organization that provides services to third parties, especially with regard to operational risk, business continuity, information security, as well as cybersecurity.

The goals of the business continuity management system are to ensure the availability of critical processes and compliance with regulations; provide role and responsibility guidelines for business continuity management; recover critical services, safeguarding the protection and safety of people, and safeguard the safety of all people who are in the DCV premises.

Redundancies and other measures taken by the IMF to ensure operational continuity include mirror disks, multiple servers (clusters), dual external power providers, dual external power lines, generators, dual fiber connections, or optical cable.

Data is replicated in real-time between the primary server and backup servers to minimize potential data loss. Operations can be switched from the primary site to the secondary site in less than an hour. In a catastrophic scenario involving the loss of primary and secondary sites, the existence of a third disaster recovery site or "SRAD" allows for an Objective Recovery Time (RTO) of 2 hours. Also, regarding the recovery copy of the data, the Recovery Point Objective (RPO) is 0 seconds. It should be added that for the DCV the Maximum Interruption Period has been defined as 2 days. The aforementioned thresholds have been made explicit in a document "Business Continuity Strategies" approved by the board of directors.

Other business continuity mechanisms include staff working from home and service level agreements with all your relevant service providers.

#### Secondary Site

The DCV has two alternate processing sites. Both are TIER 3 certified by the Uptime Institute, that is, they correspond to a Concurrently Maintainable data center with 99.982% availability, allowing maintenance activities to be planned without affecting the computer service, with redundant components and connected to multiple electrical distribution and cooling lines, but only with one active.

Both processing sites are located at a sufficient geographical distance from the primary site and from each other to present a distinct risk profile. Access to both alternate sites is basically structured as remote access.

### Review & Testing

In accordance with the provisions of the ISO 22301 standard according to which DCV has been certified, business continuity and technological contingency plans are tested at least once a year. Depositors have participated in the tests, as well as the other FMIs operating from their main site and their alternative processing site, verifying connectivity to the primary and alternative processing sites of the DCV.

The primary and secondary sites are rotated periodically. The DCV tests its remote access to the system on a weekly basis.

The DCV is a participant in the business continuity committee that is led by the BCCH and brings together the other FMIs in Chile. In the context of this committee, a series of continuity tests have been carried out with the participation of all FMIs. In the case of market-level initiatives, the committee is working on a crisis management protocol between the IMF and the BCCH, and exercises have been conducted, but partially, to simulate specific failures. Recently, the DCV has begun trials with ComBanc in order to test alternative messaging channels.

**Key consideration 7: An FMI should identify, monitor, and manage the risks that key participants, other FMIs, and service and utility providers might pose to its operations. In addition, an FMI should identify, monitor, and manage the risks its operations might pose to other FMIs.**

### Risks to the IMF's own operations

The DCV may be exposed to reputational risk in the event that other interconnected FMIs are experiencing operational problems, as they are not in a position to provide their services efficiently and reliably.

With respect to its other non-CSD services, the DCV is also exposed to certain risks as part of its securities administration activities. In addition, the securities transfer service that the DCV makes available to its depositors in conjunction with ComBanc's DVP Switch, which in turn settles payments in the BCCH's RTGS System, could be affected by a failure in either of these two IMFs.

In order to monitor risk exposures generated by other parties, the DCV uses alerts, automatic controls, and participant feedback. The IMF monitors *these risks on an ongoing basis and reviews risk management tools once a year.*

### Risks to other IMFs

The DCV poses operational risks to other FMIs, including in particular the RTGS, ComDer and CCLV system (both as a CCP and SSS). The FMIs that may not be able to function properly in the event that the CSD experiences a failure are the BCCH's RTGS system, while ComDer and CCLV would not be able to carry out their collateral management activities. In addition, the CCLV would not be able to transfer ownership of the securities of its activities, either acting as SSS or CCP.

The DCV is a participant in the Business Continuity Committee that is led by the BCCH and that brings together other FMIs such as the RTGS system, ComBanc, etc.

## Principle 18. Access and Participation Requirements

An FMI should have objective, risk-based, and publicly disclosed criteria for participation, which permit fair and open access.

**Key consideration 1: An FMI should allow for fair and open access to its services, including by direct and, where relevant, indirect participants and other FMIs, based on reasonable risk-related participation requirements.**

### Participation Requirements

Article 2 of Law 18,876 and Chapter 4 of the Internal Regulations specify the entities that may become depositors in the DCV. The list is relatively long, and includes a provision stating "any others that the company approves."

The Internal Regulations also refer to issuers of securities as participants. Therefore, all issuers of securities subject to public offerings, as well as banks and government entities in their role as issuers of securities are also considered as participants in the DCV.

Other types of participants considered in the Internal Rules are the other FMIs, as well as the other entities that a securities issuer designates as its payer in relation to company shares, payment coupons, etc.

The participation requirements essentially relate to ensuring adequate connectivity with the DCV technology platform (section 5.7 of the Internal Rules). Participants are required to maintain an active connection to the primary and secondary processing sites, which must ensure the connection to the third site (SRAD) via the Internet.

**Key consideration 2: An FMI's participation requirements should be justified in terms of the safety and efficiency of the FMI and the markets it serves, be tailored to and commensurate with the FMI's specific risks and be publicly disclosed. Subject to maintaining acceptable risk control standards, an FMI should endeavor to set requirements that have the least-restrictive impact on access that circumstances permit.**

### Justification and rationale of participation criteria

The DCV participation requirements are limited to ensuring adequate connectivity with the DCV technology platform, which is an essential requirement to ensure safe operations. The requirement for limited access to adequate connectivity is as unrestrictive as possible.

### Disclosure of criteria

Criteria for becoming a participant in DCV are specified in the Rulebook, which is publicly available through DCV's website.

**Key consideration 3: An FMI should monitor compliance with its participation requirements on an ongoing basis and have clearly defined and publicly disclosed procedures for facilitating the suspension and orderly exit of a participant that breaches, or no longer meets, the participation requirements.**

Compliance Monitoring

The DCV can monitor participants' ongoing compliance with the access criteria online.

Suspension and orderly exit

Title 20 of the Internal Rules deals with sanctions against DCV participants. A participant who repeatedly violates a law, the regulations of the law, the Internal Regulations, circulars of the DCV and/or the contract signed with the DCV, may be excluded from the system. In particular, if a participant commits the same violation three times, he/she may be suspended for 15 days, not being able to operate on the DCV technology platform. In the event of an additional violation of the same type, or a violation that is considered serious, the participant may be permanently excluded.

## Principle 19. Tiered Participation Arrangements

An FMI should identify, monitor, and manage the material risks to the FMI arising from tiered participation arrangements.

**Key consideration 1: An FMI should ensure that its rules, procedures, and agreements allow it to gather basic information about indirect participation in order to identify, monitor, and manage any material risks to the FMI arising from such tiered participation arrangements.**

There is no tiered participation at the DCV. DCV depositors keep their own securities holdings and those of their customers in separate accounts, which are readily identifiable to DCV.

On this basis, Principle 19 is deemed not applicable to DCV.

**Key consideration 2: An FMI should identify material dependencies between direct and indirect participants that might affect the FMI.**

In accordance with key consideration 1, this principle is considered not applicable to CSD.

**Key consideration 3: An FMI should identify indirect participants responsible for a significant proportion of transactions processed by the FMI and indirect participants whose transaction volumes or values are large relative to the capacity of the direct participants through which they access the FMI in order to manage the risks arising from these transactions.**

In accordance with key consideration 1, this principle is considered not applicable to CSD.

**Key consideration 4: An FMI should regularly review risks arising from tiered participation arrangements and should take mitigating action when appropriate.**

In accordance with key consideration 1, this principle is considered not applicable to CSD.

## Principle 20. FMI Links

An FMI that establishes a link with one or more FMIs should identify, monitor, and manage link-related risks.

**Key consideration 1: Before entering into a link arrangement and on an ongoing basis once the link is established, an FMI should identify, monitor, and manage all potential sources of risk arising from the link arrangement. Link arrangements should be designed such that each FMI is able to observe the other principles in this report.**

In addition to the links with the other Chilean FMIs: CCLV, ComDer, ComBanc and the Central Bank of Chile (see Chapter III), the DCV maintains links with foreign CSDs, namely in Mexico (Indeval), Colombia (Deceval) and Peru (Cavali), as well as with Citi in the United States and Euroclear in Belgium. Liaison with foreign CSDs consist of cross-shareholdings of depository accounts in the respective systems in order to be able to perform custody of foreign securities for local depositors and investors. The DCV also maintains a liaison with Citibank to operate in the Latin American, European and Asian markets.

The DCV has a “Policy for Contracting with International Custodians”, which establishes guidelines for analyzing, reviewing, and liaising with international custodians. When deciding on the establishment of a link, the DCV analyzes and takes into account legal risks, custody risks and operational risks and reviews the identified risks annually and whenever changes arise.

**Key consideration 2: A link should have a well-founded legal basis, in all relevant jurisdictions, that supports its design and provides adequate protection to the FMIs involved in the link.**

Links with foreign FMIs are contract-based. The contracts specify the applicable law: With respect to the principles of purpose, irrevocability, protection of rights, and protection of transactions processed through these foreign systems, the contracts state that all of these principles shall be governed by the laws and regulations of the issuing CSD.

In the context of the above-mentioned International Custodian Recruitment Policy, before establishing a liaison, the DCV conducts due diligence to ensure that the liaison has a well-founded legal basis. Title 15 of the DCV Internal Regulations, which is approved by the CMF, regulates the DCV to interact with foreign CSDs and global custodians to offer foreign securities custody services to local residents.

**Key consideration 3: Linked CSDs should measure, monitor, and manage the credit and liquidity risks arising from each other. Any credit extensions between CSDs should be covered fully with high quality collateral and be subject to limits.**

Credit extensions and overdrafts are not permitted in any of the DCV's contracts with other CSDs, nor does the DCV provide liquidity facilities as part of these agreements. Transactions are made if and only if the securities and funds are available and transferable.

**Key consideration 4: Provisional transfers of securities between linked CSDs should be prohibited or, at a minimum, the retransfer of provisionally transferred securities should be prohibited prior to the transfer becoming final.**

DCV does not allow for the provisional transfer of securities in any of its links with other CSDs.

**Key consideration 5: An investor CSD should only establish a link with an issuer CSD if the arrangement provides a high level of protection for the rights of the investor CSD's participants.**

When the DCV acts as an investor CSD, the DCV operates as an account holder with the issuing CSD (CSD in which the securities are issued or frozen) and the DCV appears as the holder of the securities in the issuing CSD's registry. All contracts with DCV to which a link is maintained specify that the securities are owned by the clients of the DCV and that in no event may these securities be used to finance or in any way support an obligation or liability of the DCV or the other CSD. In addition, the DCV performs a daily reconciliation of its securities registry specifically to its depositors with foreign securities with respect to the total balances available in their accounts in the foreign CSDs.

The Policy on the Recruitment of International Custodians establishes the obligation to verify that the legal aspects, in particular the conditions of contracting the CSD in its capacity as an investor CSD in a foreign CSD, guarantee that the rights of its depositors are fully safeguarded.

**Key consideration 6: An investor CSD that uses an intermediary to operate a link with an issuer CSD should measure, monitor, and manage the additional risks (including custody, credit, legal, and operational risks) arising from the use of the intermediary.**

Not applicable.

**Key consideration 7: Before entering into a link with another CCP, a CCP should identify and manage the potential spill-over effects from the default of the linked CCP. If a link has three or more CCPs, each CCP should identify, assess, and manage the risks of the collective link arrangement.**

Not applicable.

**Key consideration 8: Each CCP in a CCP link arrangement should be able to cover, at least on a daily basis, its current and potential future exposures to the linked CCP and its participants, if any, fully with a high degree of confidence without reducing the CCP's ability to fulfil its obligations to its own participants at any time.**

Not applicable.

**Key consideration 9: A TR should carefully assess the additional operational risks related to its links to ensure the scalability and reliability of IT and related resources.**

Not applicable.

## Principle 21: Efficiency and Effectiveness

An FMI should be efficient and effective in meeting the requirements of its participants and the markets it serves.

**Key consideration 1: An FMI should be designed to meet the needs of its participants and the markets it serves, in particular, with regard to choice of a clearing and settlement arrangement; operating structure; scope of products cleared, settled, or recorded; and use of technology and procedures.**

The DCV is owned by its depositors, who are represented on the board in a proportion reasonably aligned with their share of the intensity of use of the DCV's services (see Principle 2).

In addition to having an indirectly elected board of directors, the DCV interacts with depositors through regular meetings with specific user groups and through the annual General Depositors' Assembly when major changes are proposed. The DCV also receives recommendations from the Supervisory Committee (see Principle 2). In addition, the DCV has implemented a body called the "Depositors' Committee" under which the development of DCV initiatives is presented, and the opinions and concerns of depositors are raised.

Additionally, the DCV carries out customer satisfaction surveys on a quarterly basis, which measures the perception of depositors regarding the overall evaluation of services, availability of services, response times, operational continuity in the face of Covid-19 contingency, and attention received from the customer service desk, among other aspects.

**Key consideration 2: An FMI should have clearly defined goals and objectives that are measurable and achievable, such as in the areas of minimum service levels, risk-management expectations, and business priorities.**

The DCV has developed a balanced scorecard called the "Corporate Balanced Scorecard" (Corporate BSC), which is ratified by the Board of Directors and additionally supported by a letter signed by the Chairman of the Board in which the commitments are formalized. The Corporate BSC encompasses four perspectives:

- Financial perspective mainly in relation to efficiency in spending.
- Customer-product-market perspective, including customer satisfaction, quality of operations, and revenue by line of business with a special focus on new business, etc.
- Perspective of the internal organization including aspects of commitment and training.
- Risk management perspective including compliance with the Risk Management Policy and specific policies.

**Key consideration 3: An FMI should have established mechanisms for the regular review of its efficiency and effectiveness.**

Compliance with goals and objectives is reviewed quarterly by the board of directors and board committees.

The indicators are measured on a monthly basis and feed into the quality assurance system and internal controls system to encourage continuous process improvement.

**Principle 22: Communication procedures and standards**

**An FMI should use, or at a minimum accommodate, relevant internationally accepted communication procedures and standards in order to facilitate efficient payment, clearing, settlement, and recording.**

**Key consideration 1: An FMI should use, or at a minimum accommodate, internationally accepted communication procedures and standards.**

*Communication Procedures and Standards*

The DCV provides a web-based communications system for its communications with its depositors. The messaging standard used in this case is also proprietary and based on the ISO 15022 standard. For its communications with other IMFs in Chile, i.e. ComBanc, ComDer and the Central Bank, DCV uses SWIFT messaging.

### Principle 23: Disclosure of Rules, Key procedures, and Market Data

An FMI should have clear and comprehensive rules and procedures and should provide sufficient information to enable participants to have an accurate understanding of the risks, fees, and other material costs they incur by participating in the FMI. All relevant rules and key procedures should be publicly disclosed.

**Key consideration 1: An FMI should adopt clear and comprehensive rules and procedures that are fully disclosed to participants. Relevant rules and key procedures should also be publicly disclosed.**

#### Rules, Procedures, and Disclosure

The regulations adopted by the DCV are contained in the Internal Regulations of the CSD, as well as in internal circulars and contracts with depositors, issuers and other IMFs. Both the Internal Regulations and the Internal Circulars are published on the DCV website.

**Key consideration 2: An FMI should disclose clear descriptions of the system's design and operations, as well as the FMI's and participants' rights and obligations, so that participants can assess the risks they would incur by participating in the FMI.**

The DCV provides depositors with information regarding the operation of the system, including process diagrams. The Internal Rules and especially the internal circulars describe detailed information on the rights and obligations of the participants and the FMI, but also on the description of the activities or services developed by DCV and the design and operation of the system. In addition, on its website, the DCV has uploaded a series of corporate presentations with detailed information on the general design of the DCV, the services offered, the applicable risk management and other relevant aspects.

The rights and obligations, as well as the risks incurred by participants through participation in the DCV, are explained throughout the Internal Rules, and are further specified in the contracts signed by DCV depositors.

**Key consideration 3: An FMI should provide all necessary and appropriate documentation and training to facilitate participants' understanding of the FMI's rules and procedures and the risks they face from participating in the FMI.**

Upon becoming a depositor in the DCV, participants are provided with the relevant rules and procedures, operational guidelines and technical information on the DCV technology platform, including a detailed user manual.

The means described above are generally sufficient to ensure a participant's good understanding of the rules, procedures, and risks they face when participating as DCV depositors. In general, many operators have years of experience interacting with the DCV system.

The DCV contemplates a training scheme for all users every time relevant developments are launched on the operational platforms.

**Key consideration 4: An FMI should publicly disclose its fees at the level of individual services it offers as well as its policies on any available discounts. The FMI should provide clear descriptions of priced services for comparability purposes.**

The fee structure of the DCV is described in detail in Title 19 of the Internal Rules, which, as indicated, is a public document. The fee structure can also be accessed directly on the DCV website.

Fee information is broken down at the level of each service and includes overhead (e.g., monthly fee, custody fees, etc.), deposit account charges, including securities transfer services, inventory account fees, trade record service charges, and other charges.

The information for each of the services is detailed, differentiating by type of instrument, type of transaction, etc. Information on discounts is also provided and regulated in section 20.10 of the Regulations.

**Key consideration 5: An FMI should complete regularly and disclose publicly responses to the CPSS-IOSCO disclosure framework for financial market infrastructures. An FMI also should, at a minimum, disclose basic data on transaction volumes and values.**

The DCV develops statistics in relation to trading volumes, which are available to the public on its website. The Annual Report also provides operational and financial information.

In addition, the DCV has completed the CPMI-IOSCO Disclosure Framework for Financial Market Infrastructures, which is updated and published at least every two years.